



SPEED, INC.

**Detroit Speed, Inc.
LS Engine Mount Kit
1982-92 F-Body
P/N: 060435**

The Detroit Speed, Inc. LS Engine Mount Kit will provide you with an easy, no hassle installation of any LS engine into your 1982-92 F-Body application. This kit includes powder coated frame side engine mount stands, CNC aluminum adapter plates, polyurethane engine mounts and all necessary hardware. This kit will also move the LS engine location back approximately 3/8" from the stock Small Block Chevy engine location.



| Item # | Description | Quantity |
|--------|-------------------------------------|----------|
| 1 | Engine Mount Adapter Plate, LH & RH | 2 |
| 2 | Engine Mount Bracket, LH & RH | 2 |
| 3 | Polyurethane Engine Mounts | 2 |
| 4 | M10 x 1.5 x 30 Countersunk Bolt | 2 |
| 5 | M10 x 1.5 x 30 Flange Head Bolt | 4 |
| 6 | M10 x 1.5 x 20 Flange Head Bolt | 4 |
| 7 | M10 x 1.5 x 40 Flange Head Bolt | 2 |
| 8 | 7/16"-14 x 3.75" Hex Head Bolt | 2 |
| 9 | 7/16"-14 Hex Nut | 2 |
| 10 | 7/16" Flat Washer | 4 |
| 11 | 7/16" Lock Washer | 2 |
| 12 | M10-1.5 x 25 Flange Head Bolt | 6 |
| 13 | M10 x 1.5 Hex Flange Locknut | 6 |
| 14 | Instructions | 1 |

| Fastener Torque Specifications | |
|--|------------------|
| Application | Torque (ft./lbs) |
| Adapter Plate to Engine Block (Aluminum Block) | 25 |
| Adapter Plate to Engine Block (Cast Iron Block) | 35 |
| Engine Mount to Adapter Plate (Upper Bolts) | 25 |
| Engine Mount to Adapter Plate (Lower Bolt - Aluminum Block) | 25 |
| Engine Mount to Adapter Plate (Lower Bolt - Cast Iron Block) | 35 |
| Engine Mount Bracket to Crossmember (Bolt Side) | 38 |
| Engine Mount Bracket to Crossmember (Nut Side) | 30 |
| Engine Mount Bracket to Engine Mount | 30 |

1. To begin installation, locate the engine mount adapter plates in the kit. The milled side of the mount will face away from the engine with the smooth side going to the block. The end of the adapter plate with the angle cut will go to the front of the vehicle.
2. To mount the engine mount adapter plate to the engine, use two M10x1.5x30 flange head bolts (#5) and one M10x1.5x30 countersunk bolt (#4) per side. Use anti-seize on these bolts. On aluminum engine blocks, torque the bolts to 25 ft./lbs and on cast iron blocks, torque to 35 ft. /lbs.
3. The engine mount will install next. Use two M10x1.5x20 flange head (#6) bolts in the top of the mount and one M10x1.5x40 flange head bolt (#7) in the bottom of the mount. Torque the upper bolts into the adapter plate to 25 ft. /lbs. For the lower bolt, torque to 25 ft./lbs. on an aluminum block and 35 ft./lbs. on a cast iron block. Again, use anti-seize on these bolts.
4. Attach the engine mount bracket to the crossmember using three M10-1.5x25 flange head bolts (#12) and three M10x1.5 prevailing torque hex flange locknuts (#13) per side. **NOTE:** Be sure to have the correct side engine mount bracket as there is a LH and RH bracket that are mirror images of each other. Use High Strength Red Loctite (p/n: 262) when installing these bolts. If you have the torque wrench on the bolt, torque to 38 ft./lbs. and if you have the torque wrench on the nut, torque to 30 ft./lbs.
5. Once everything is positioned correctly on the crossmember and engine, attach the engine to the engine mount bracket using two 7/16"-14x3.75" hex head bolts (#8). Use the provided flat washers (#10), lock washer (#11) and the hex nut (#9) to tighten everything in place. Torque these bolts to 30 ft. /lbs. Installation is now complete.

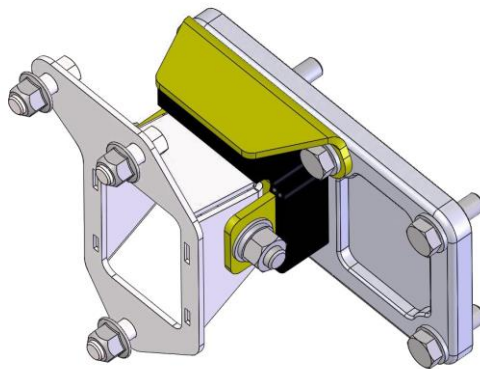

If you have any questions before or during the installation of this product please contact Detroit Speed Inc. at info@detroitsspeed.com or 704.662.3272

Legal Disclaimer: *Detroit Speed, Inc. is not liable for personal, property, legal, or financial damages from the use or misuse of any product we sell. The purchaser is solely responsible for the safety and performance of these products. No warranty is expressed or implied.*